

Listening and Study Strategies for Elementary Language Learners

Ben Cookus and Caleb Smith

General Tips

- Studying is difficult!
- What you're trying to remember has to be important
 - Important to us
 - Important to our daily lives
 - Important to the moment
- Understanding is Key!
- Simple is hard to forget.
- Short term memory is consolidated during sleep
- Study with friends! (Immersion helps)



Active Recall

- Active Recall: study method that involves retrieving information from memory without looking back at your study materials

Implementations

- Quizzing yourself
- Writing down questions instead of notes
- Flashcards!!!



Interweaving

- Interleaving is a learning technique in which learners mix, or interleave multiple topics or subjects while studying to improve their learning process.

Implementations

- Interweave new material with old material.
- Before exams study each topic in a cycle.

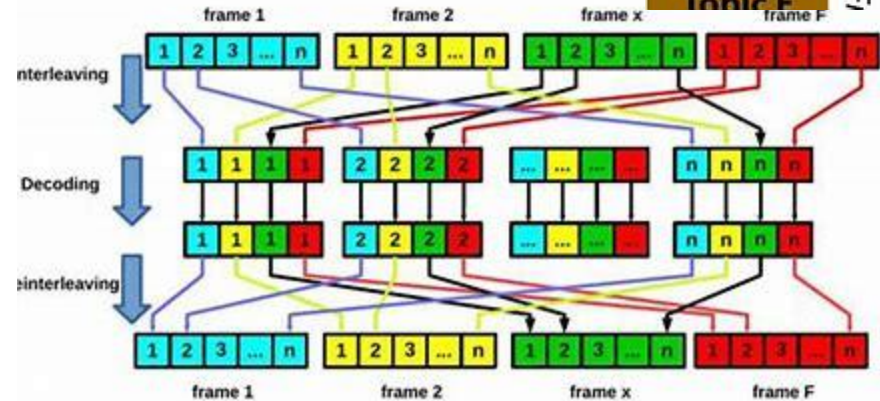
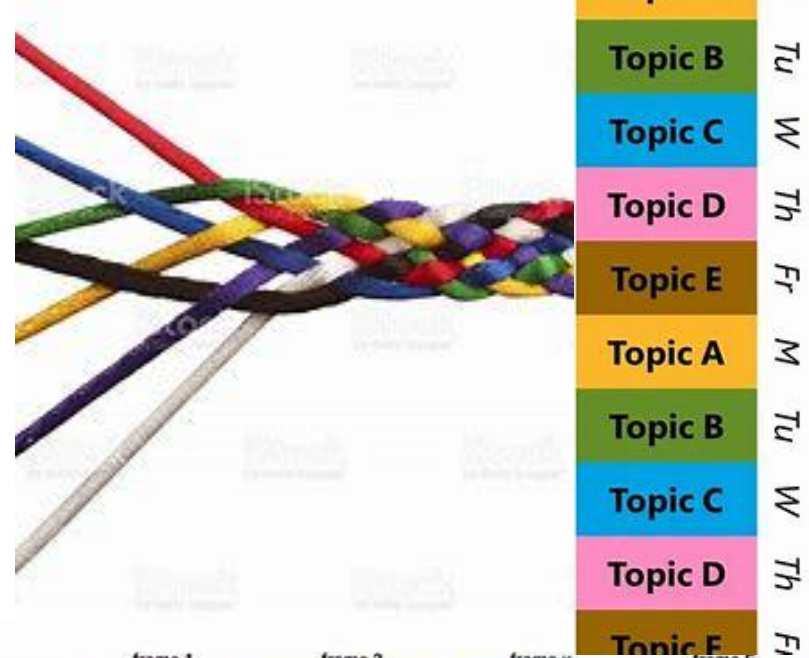

General Tips

- Studying is difficult!
- What you're trying to remember has to be important
 - Important to us
 - Important to our daily lives
 - Important to the moment
- Understanding is Key!
- Simple is hard to forget.
- Short term memory is consolidated during sleep
- Study with friends! (Immersion helps)



Make your language important to your daily life

- Spaced repetition
 - Longer and longer spaces
- Write ten sentences a week
- Make your workspace for your work

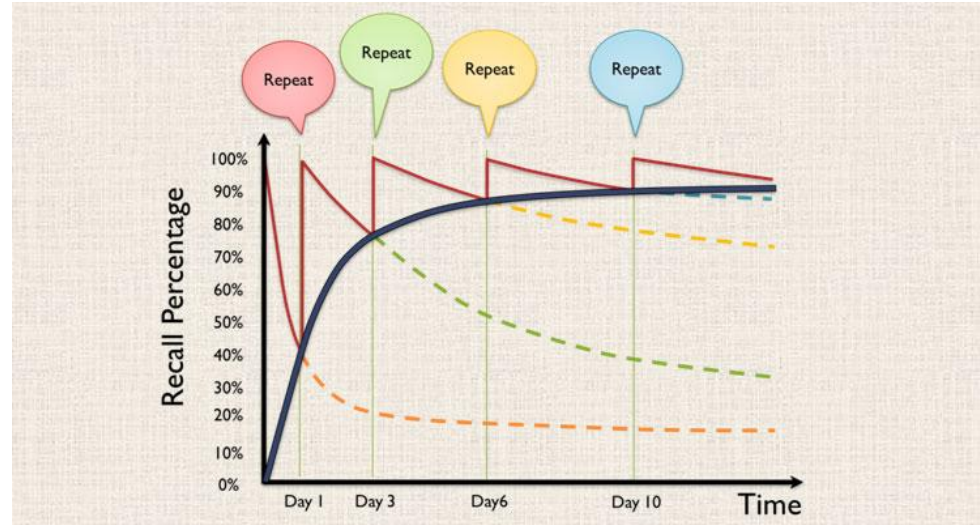

General Tips

- Studying is difficult!
- What you're trying to remember has to be important
 - Important to us
 - Important to our daily lives
 - Important to the moment
- Understanding is Key!
- Simple is hard to forget.
- Short term memory is consolidated during sleep
- Study with friends! (Immersion helps)



Study with friends

- Increases brain activity in areas related to oxytocin, dopamine, and Norepinephrine
- Helps with motivation
- Allows you to associate learning with having fun.
- Increases immersion - people to practice with
- Office hours



Classroom Strategies

- Be engaged in what is happening (answer questions, ask questions)
- If you miss a lecture, email the professor or ask a friend for the notes from that lecture and make sure you understand them
- Go to Office/Study Hours
- While there, ask questions you have about concepts you do not fully understand
- Also utilize Office/Study Hours to practice concepts in front of the professor so you can solidify those concepts
- After exams, go to Office/Study Hours to identify knowledge gaps from the exam and then create a plan/method to fill those gaps for the next exam or final

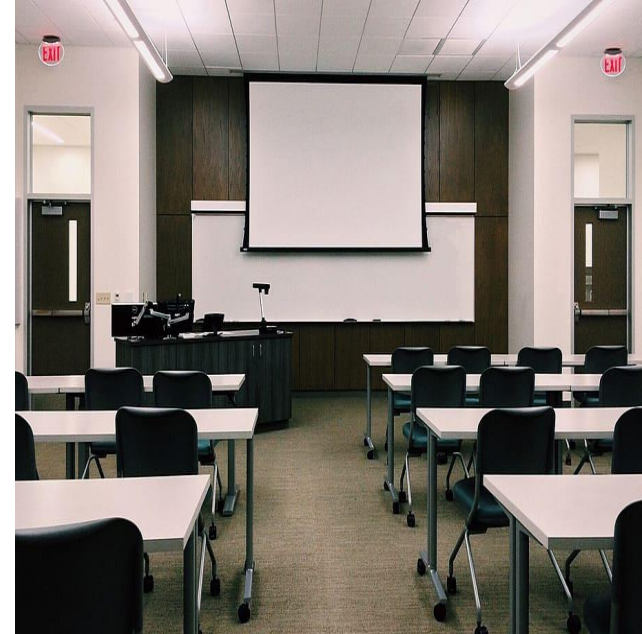

Listening Strategies

- Be an active listener
- Acclimate to the sound of the language
- Identify key words (nouns, verbs, subject)
- Use the speed slider/replay parts that you are iffy on
- Find transcripts/subtitles if possible to help with recognition
- Listen to something in English and then German or vice versa
- Create your own audio tracks
- Find audio resources meant for education
- Find additional conversational resources not meant for education



Listening Resources

- Deutsche Welle (Learn German)
- Easy German (YouTube)
- News in Slow German (Website)
- Coffee Break Podcast (apple podcast, podcast player...)